

Behavior of plate foundation in deep excavation beneath 32-storey building in Moscow

A.V. Skorikov, D.E. Razvodovsky, I.V. Kolybin

Research Institute of Bases and Underground Structures, Moscow, Russia

A.A. Starshinov

Centre for Foundation Engineering Problems, Moscow, Russia

ABSTRACT: The paper describes the case history of construction of two levels underground car park beneath multistory building in Moscow. The building consists of five parts. Plate foundations were used in soft soil conditions. The complex of software including *Plaxis* and *ProFEt&STARK* was used to predict the settlements. The calculation showed that predicted settlements of each separate part of the building were almost uniform and did not exceed 14 cm. Predicted tilt and relative differential settlement were less than 0.002. These results were compared with monitoring data.

1 INTRODUCTION

The main tendency of modern construction in Moscow is to create multistory buildings with several underground floors. The choice of appropriate foundation design in many cases is complicated. In the most cases an engineer is choosing between pile foundations, plate or combined foundations. According to Russian design Codes the mean settlement of a building should not exceed 12-15 cm, and the maximum value of allowed tilt must be less than 0.002-0.0024. Due to Moscow building Code pile foundations are recommended in all cases when the mean value of contact pressure exceeds 500 kPa. Thus the prediction of total and differential settlements is one of the main tasks for geotechnical design. The numerical FEM modeling combined with local experience is the way to solve this problem.

The authors had an opportunity to design foundations in deep excavation for multistory building constructed on soft soil in Moscow. Plate foundations were chosen for design. Settlements of the building were monitored during construction process.

2 THE STRUCTURE

The sub-structure consists of two levels of underground car park beneath multistory building. The constructed building includes five separated parts from A to E (Fig 1). The location of construction parts is shown in Fig 2. Technical characteristics of all parts of the building are presented in Table 1.

Table 1. Technical characteristics of construction parts of the building.

	Parts A, C	Part B	Part D	Part E
Plan dimensions:				
Length (m)	29.5	80.0	59.1	32.4
Width (m)	20.8	22.1	21.6	21.0
Building height (m)	80.6	104.6	32.9	14.7
Depth of underground part (m)	7.2	8.0	7.1	9.6
Number of underground floors	2	2	2	3
Height of underground floors (m)	3.0 and 3.3	3.0 and 4.5	3.0 and 3.6	3.0
Number of storeys	24	32	10	3

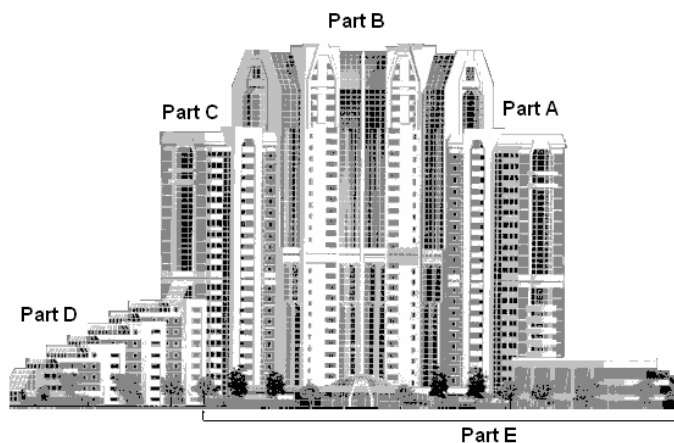

Figure 1. Elevation of building

The excavation depth at the site varied from 8 to 10 m. The retaining wall of steel pipe elements braced with one level of struts was constructed in order to provide stability of the excavation. The inclined struts were based on special temporary reinforced concrete supports that were cast under foundation slabs.

Mean normal stress exerted by the highest part B to the soil was nearly 550 kPa. Pressures under construction parts A and C did not exceed 450 kPa. Movement joints separated all parts of the complex.

Main bearing structural elements of the building were done with in situ cast reinforced concrete. Cross-section of underground part of block B is shown in Fig. 3.

At the early stages of design it was obvious that the use of plate foundations would be preferable due to economical reasons. The construction of heavy buildings based on foundation slabs in soft soils demanded thorough investigation to predict total and differential settlements. This prediction governs to decide whether the settlements are to be tolerated by the design of the structure. That is why the complex of numerical calculations was conducted.

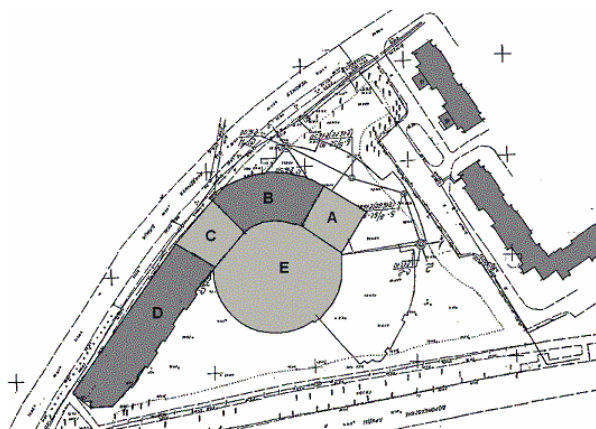

Figure 2. Building plan and surrounding buildings.

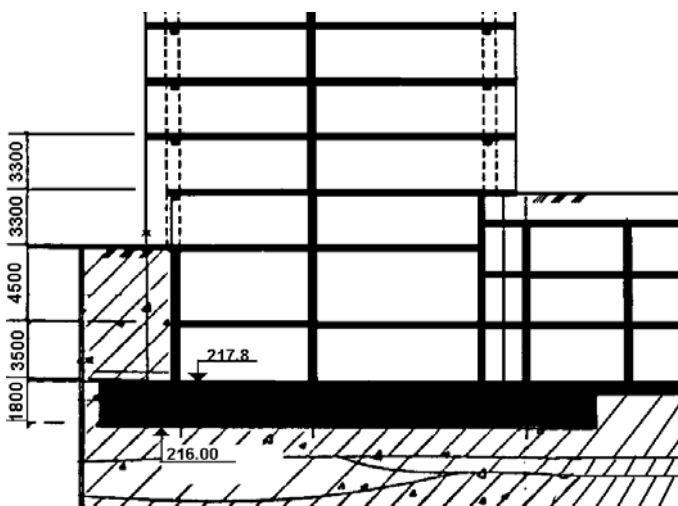

Figure 3. Underground part of the building

3 GEOLOGICAL CONDITIONS

The subsoil consists of fill 1.5 to 2.5 m thick. The fill in this part of Moscow is presented by sand, crushed stone and pebble. Alluvial quaternary clays and loams follow the fill. Loams and sandy clays underlay alluvial sediments.

Typical geological profile beneath the foundations is shown in Fig 4. Analysis of soil conditions showed that there was neither evidently bearing nor extremely weak soil layer within strata.

Confined groundwater was met at the depth of 12-18 m in sandy lenses within loam deposits. The hydraulic head in these lenses reaches from 3 to 5 m.

4 CALCULATIONS

4.1 Preliminary calculations

Simple calculations of mean settlements based on elasticity theory were conducted at the initial stage of study. Thickness of the compressed soil layer beneath the foundation was determined according to Russian standards (SNIP, 1985):

$$H = (H_o + \psi b)k_p \quad (1)$$

where H - the thickness of compressed layer:

H_o - 9 m (for clayed soils);

ψ - 0.15 (for clayed soils);

b - the width of foundation;

k_p - pressure dependent coefficient, $k_p = 0.8$ when net pressure under foundation is equal 100 kPa and $k_p = 1.2$ when net pressure is equal 500 kPa.

The thickness of compressed layer received from Eq. (1) was accepted in further calculations. Method of elastic layer was used for calculation of mean settlements to make preliminary analysis of the serviceability requirements for each part of the building.

Elevation (m)	SOIL TYPE	SOIL PROPERTIES			
		γ , kN/m ³	ϕ , deg.	C , kPa	E , MPa
216.0	hard clay	19,5	13	45	14
214.0					
207.0	loam	20,1	15	30	17
202.0	loam	20,9	18	46	31
200.0	hard clay	20,6	17	50	33
195.0	loam	20,9	18	46	31
190.0	hard clay	18,4	22	50	22

Figure 4. Geological strata under foundation.

Preliminary calculated settlements occurred to be less than Codes recommended values (SNIP, 1985) and design of plate foundations was started.

Thickness of foundation slabs was determined from calculation of their punching. It was taken in further design – 1300 mm for parts A and C, 1800 mm – for part B, 800 mm – for part D.

After this first stage of analysis the values of differential settlements were to be examined. To predict differential settlements the complex of FE software such as *Plaxis* and *ProFEt&STARK* was used.

4.2 *Plaxis* calculations

Plaxis finite element code was used for prediction of non-uniform settlements. A two-dimensional finite element analysis was conducted to model the soil-structure interaction using isoparametric triangular elements with 15 nodes and beam elements. Elastic-perfectly plastic analysis using the advanced Mohr-Coulomb model was carried out. Different values of stiffness modulus of soil elements were used in calculations for unloading and reloading of the massif. Numerical analysis was performed in order to define the plastic part of the settlement and to determine the base stiffness factors for further 3D calculations with springs model. Local zones of plastic deformations in soil were detected.

The comparison between elastic and elastic-plastic *Plaxis* models was performed. The most significant conclusion from *Plaxis* calculations was that predicted tilts of parts A, B and C essentially depended on calculation model. Different direction of the building tilt was obtained using elastic and Mohr-Coulomb models as it is shown in Fig. 5 and 6. Maximum value of calculated settlements differed for more than 30% comparing these two models. Cross-sectional distribution of foundation settlements referred to the mentioned models is presented in Fig. 7.

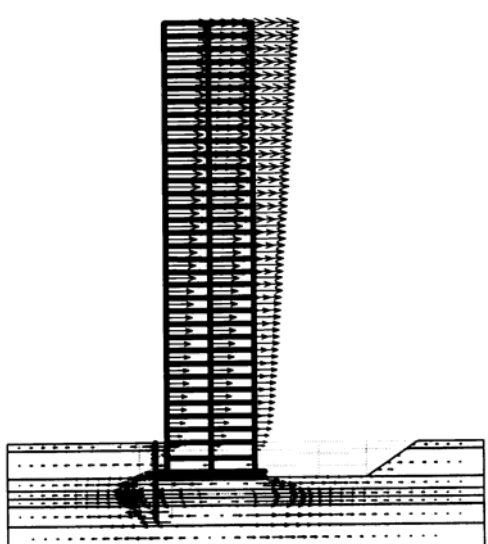

Figure 5. Horizontal displacements of the part B (elastic solution)

Differences in calculated deformations by elastic and elastic-plastic solutions may have the following explanation. Due to constructional peculiarities of the building normal stresses under foundation slabs were higher at the side of open excavation and lower at the side of retaining wall. Thus the elastic solution gave a small tilt to the right in Fig. 5 and 7.a. The modified Mohr-Coulomb model took into account a plastic zone in soil massif adjacent to retaining structure. This zone was formed at the excavation stage. In this case the plastic component of settlements led to building tilt to the left in Fig. 6 and 7.b.

Outline of the foundation plates was revised on the base of this analysis in order to avoid tilt towards outside excavation.

Staged calculation took into account that foundation pit would be excavated in a single stage for all construction parts of the building. Along with this construction of part E was planned after completion of the other parts. Thus it was necessary to analyze the stability of the soil massif at the edge of high-rise parts against sliding towards open excavation of part E.

Calculations of soil stability with $c-\phi$ reduction *Plaxis* procedure were performed for parts A, B and C. These calculations showed that the value of safety factor for part B occurred to be less than 1.2 and was inadmissible for construction (SNIP, 1985).

It was recommended to construct a part of block E as a surcharge to provide soil stability. Construction of the required part of block E should be completed before erection of the twentieth storey at blocks A, B and C.

The partial surcharge of the excavation bottom increased calculated values of safety factor up to 1.24 for part B and 1.35 for parts A and C.

Predicted displacements of part B corresponding to its failure under the value of safety factor 1.14 are demonstrated in Fig. 8.

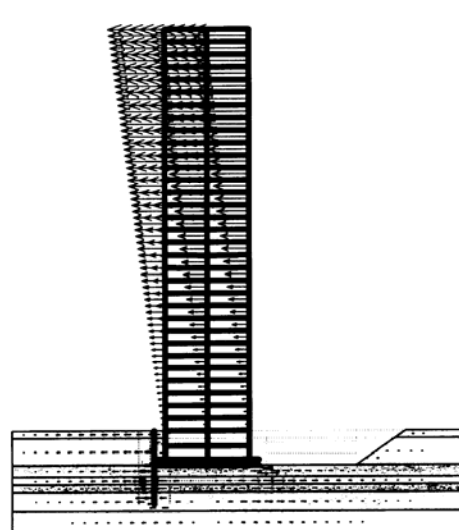

Figure 6. Horizontal displacements of the part B (Mohr-Coulomb solution)

4.3 3D finite element analysis

Finite element analysis of 3D model was done with *ProFEt&STARK* software that is used for structural engineering. The program gives possibility to analyze mechanical behavior of structure interacting with elastic soil base and to determine the required reinforcement in concrete elements according to Russian standards.

Soil base behavior was described with Winkler spring type model (where upward reaction at a point is directly proportional to the settlement of this point). Altering in plan stiffness was assumed for soil base spring model. The results of elastic-plastic staged FE analysis with *Plaxis* for plain-strain approximation were used to determine plan distribution of subgrade reaction.

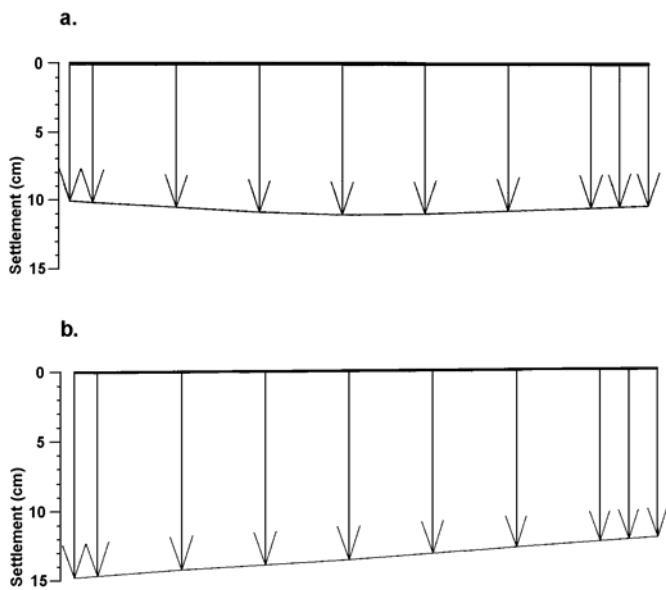

Figure 7. The distribution of predicted settlements of part B due to elastic (a) and Mohr-Coulomb (b) solution.

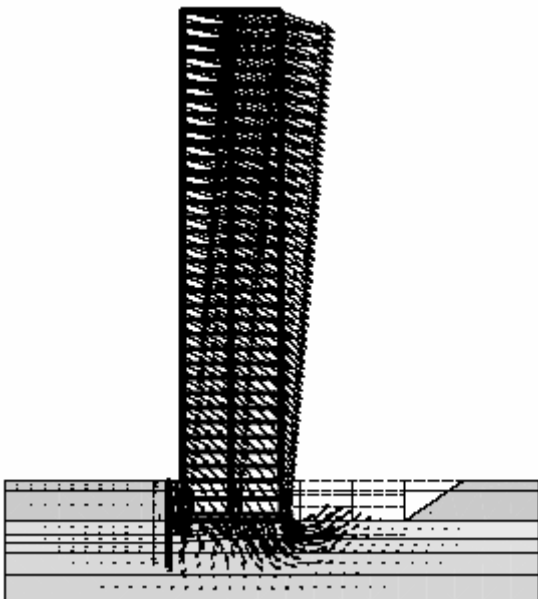

Figure 8. Failure of part B under the safety factor 1.14.

Fragment of finite element approximation for modeling of the underground part of tower B is shown in Fig. 9. Boundary conditions corresponding to the symmetry of construction were applied at the left edge of the model. Predicted values of settlements and relative differential settlements were obtained for all parts of the building. In Fig. 10 the deformed FE mesh for part B and predicted settlements are shown.

Comparison of foundation settlements calculated in 3D analysis with results of *Plaxis* simulation has demonstrated their good convergence.

Conducted 3D calculation showed that parts A, B and C of the building would receive almost uniform settlements varying within the range up to 14 cm. Predicted tilts and relative differential settlements did not exceed 0.002. Table 2 summarizes the main results of finite element analysis.

The required reinforcement in foundation slabs was also determined as the result of 3D modeling.

5 MONITORING

5.1 Monitoring program

A special monitoring program was performed to verify the design concept, to ensure the serviceability requirements and to contribute the quality control. The program included measurements of constructed building settlements, visual and instrumental control

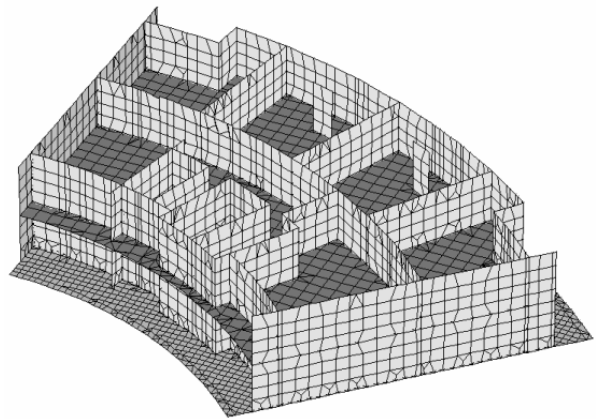

Figure 9. Finite element mesh for the underground floors of part B.

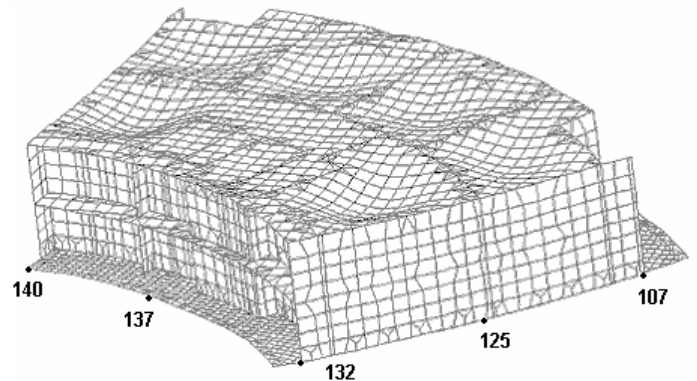

Figure 10. The deformed mesh for the underground floors of part B and predicted settlements (mm).

of the cracks behavior. Horizontal displacements of retaining wall were also monitored at the excavation stage.

Protection of adjacent buildings against a potential damage was in the focus of monitoring works performed by Centre for Foundation Engineering Problems.

Measurements of settlements were performed by leveling of special marks installed on the external walls of adjacent buildings and on the structural elements of constructed complex. Twelve marks were placed in each of foundation slabs A and C, twenty two marks – in slab of part B, seventeen – in foundation of D. Each slab mark was doubled with a mark on the wall on the occasion of its damage.

The fulfillment of monitoring program was started just before the beginning of construction. First measurements for adjacent buildings were done in January and for foundation slab A – in April 2002. Today the monitoring is continued 6 months after the completion of high-rise parts. The measurements were fulfilled once a month during the construction period and once in two months after the completion of construction.

5.2 Monitoring results

The mean load-settlement curves were obtained for construction parts as the result of *Plaxis* calculation. Measurements of the building settlements were compared with results of numerical modeling.

The comparison between monitoring data and predicted settlements and tilts is presented in Table 2. Calculated and measured settlement curves for part B are combined in Fig. 11. Measured curves are presented for the marks received the maximum and the minimum settlement.

Close correlation between monitored and calculated settlements could be seen in Fig. 11 at the first

stages of construction. To our opinion the reason for this fact is an adequate prediction of recompression effects for foundations in deep excavation.

Soil consolidation obviously is the main cause for continuation of building settlements after the completion of construction as it is seen in Fig. 11. Extrapolating monitoring curves one can conclude that the final settlements would not exceed predicted values. Exceeding of calculated settlements may be connected with overestimated values of live loads applied for numerical modeling.

Measured settlements of parts A, B and C are close to uniform. Plan of part B with indicated values of measured settlements after 27 months from beginning of construction is shown in Fig. 12. Observed tilts were small and their directions agreed with FE modeling for all construction stages. This proves that the use of non-linear models can give satisfactory results for prediction of differential settlements.

The uplift of foundation slab of part D was fixed during the monitoring. In the first winter period the foundation slab only was erected there and a surcharge at excavation bottom was very small. The in-

Table 2. Comparison between calculated and measured settlements.

Calculated value Measured value	Part A	Part B	Part C	Part D
Maximum settlement (mm)	<u>106</u> 90	<u>140</u> 101	<u>123</u> 92	<u>79</u> 68
Minimum settlement (mm)	<u>97</u> 85	<u>112</u> 83	<u>111</u> 83	<u>24</u> 26
Maximum tilt	<u>0.0005</u> 0.0002	<u>0.0010</u> 0.0005	<u>0.0007</u> 0.0004	<u>0.0018</u> 0.0015

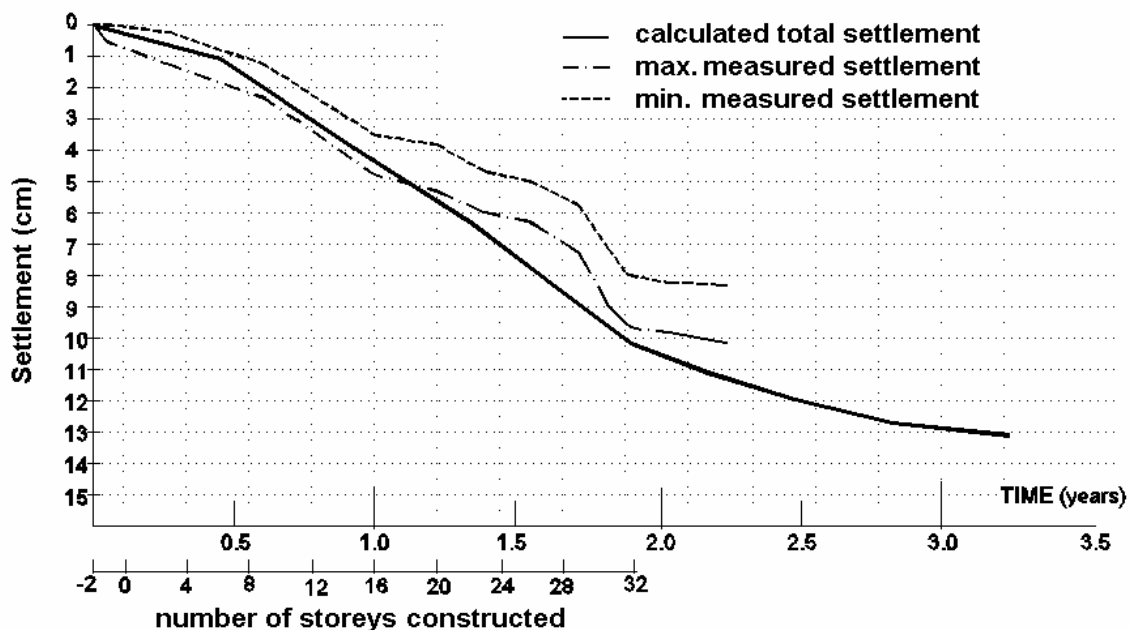

Figure 11. Comparison of monitoring data for part B with result of *Plaxis* calculation

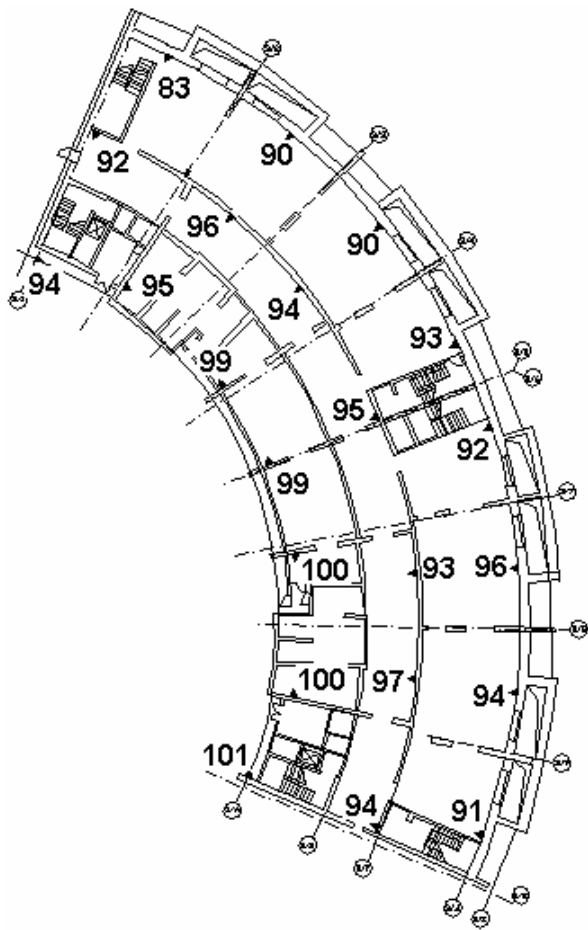

Figure 12. Measured settlement values for part B after 27 months from beginning of construction (mm).

sufficient uplift was noticed for the first in November 2002 and in spite of special warming procedure for foundation slab it developed until March when its magnitude composed 26-79 mm. This fact could not be interpreted only as soil deformations due to unloading of excavation. The most evident explanation seemed to be a frost heaving of clays. Nevertheless investigations demonstrated that moderate heaving properties of clays could not explain magnitude of deformations. The differential character of heaving was also discussible. Interpreting measured deformations of foundation slab of part D one more factor should be taken into consideration. Water level observations showed that in this part of excavation a sandy lens missed during initial investigations was situated not too much deeper then excavation bottom. This lens containing confined groundwater was disturbed during construction of supports for the struts that were cast under foundation slab. Thus seepage at the contact of foundation slab and soil could violently amplify frost heaving and explain the observed effect.

Monitoring data showed that construction slightly influenced on two adjacent buildings situated at approximately 20 m from excavation. Their settlements did not exceed 1-2 mm. New damages were not fixed on these buildings.

Construction of underground part of the building is illustrated in Fig. 13.



Figure 13. Construction of underground part of the building.

6 CONCLUSIONS

The use of slab foundations in deep excavation proved to give a good effect for construction of multistory building on soft soil. A special complex of investigations and non-linear finite element analysis was undertaken to adopt this solution. Monitoring program at the site was performed to verify the design concept.

Finite element numeric modeling discovered that prediction of differential settlements occurred to be very sensitive to soil model. In order to avoid unacceptable tilts initial outline of foundation plates was revised in design due to elastic-plastic calculation with respect to unloading of excavation.

Measurements conducted at the site demonstrated that settlements of high-rise parts A, B and C were close to uniform and tilts were negligible. Monitored values of settlements did not exceed the predicted values. Satisfactory convergence between calculated and measured settlements was achieved. It was proved that analysis based on the linear elastic base model could cause serious mistakes in design. The effects of soil recompression and plastic behavior typical for construction in deep excavation should be considered to obtain reliable prediction.

Monitoring permitted to take measures to reduce heaving of foundation slab of part D and to confirm safety of adjacent buildings.

7 REFERENCES

- MGSN 2.07-01. 2003. *Bases, foundations and underground constructions*. Moscow: MOSCOMARCHITEKTURA.
- SNIP 2.02.01-83. 1985. *Bases of buildings and structures*. Moscow: STROYIZDAT.
- Tomilson M.J. 2001. *Foundation design and construction*. Harlow: Pearson Prentice Hall.